

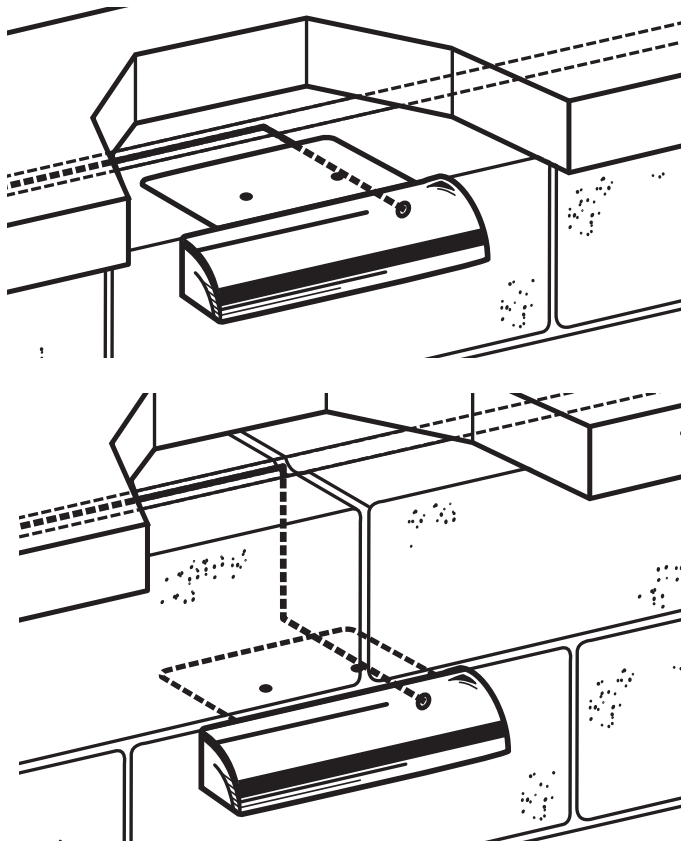

**CAST ENGINEERED WALL LIGHT – CEWL5CB, CEWL5LED1**

Project: \_\_\_\_\_ Date: \_\_\_\_\_  
 Fixture Type: \_\_\_\_\_ Quantity: \_\_\_\_\_  
 Specifier: \_\_\_\_\_

Drawings not to scale

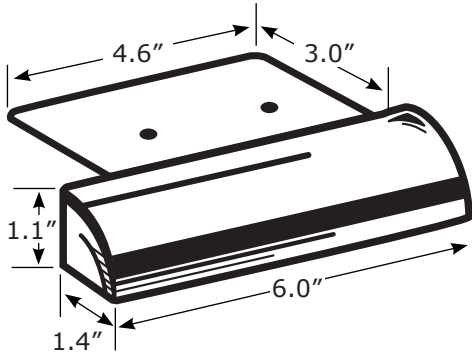

**INSTALLATION**

- ▶ Under-capstone installation – Use Set-in-Stone Wall Light Installation System.
- ▶ Between-blocks installation – Use Set-in-Stone Wall Light Installation System.

- ▶ Light source: CEWL5CB – T-3 wedge-base 10W xenogen lamp (included), 18W max; CEWL5LED1 – Replaceable LED board; 3W, 2,700K
- ▶ Optimal voltage: CEWL5CB – 10.8 to 11.3 volts; CEWL5LED1 – 8.0 to 18.0 volts
- ▶ Extremely durable solid sand-cast bronze body and 100% copper bracket.
- ▶ Frosted Soda Lime Glass enclosed lamp compartment.
- ▶ Internal reflector for optimal light distribution.
- ▶ Copper bracket can be bent, cut, or secured with screws for installation flexibility. Bracket extends off back of body so that it is concealed even when mounted between blocks.
- ▶ Lamp replacement: CEWL5CB – Lamp socket swivels outward for easy lamp replacement; CEWL5LED1 – LED board can be removed and replaced.
- ▶ Thermal management: CEWL5CB – High temperature corrosion-resistant socket; CEWL5LED1 – LED board is bonded to solid bronze body for optimal thermal transfer.
- ▶ Pre-wired with 25 ft. #18/2 tin-coated, marine-grade No-Ox wire.

Plan Symbol: XXXXXXXXXX

**MOUNTING OPTIONS**

- Flush-Mount Bracket (XCMBEWL1)
- Set-in-Stone Wall Light Mounting Module (CSIS)
- Set-in-Stone Flexible Conduit (CSISC)

**Notes**

- Typical spacing 4' to 8'
- Refer to product installation sheet prior to installation